



# Laundry Wastewater Treatment Using Down-Flow Hanging Sponge Bioreactor Process

Munawar Munawar<sup>1</sup>, Dwi Sukma Donoriyanto<sup>2</sup> Nur Rahmawati<sup>3</sup>

<sup>1</sup> Magister of Environmental science, Faculty of Engineering, Pembangunan Nasional “Veteran” Jawa timur University

<sup>2,3</sup> Industrial Engineering, Faculty of Engineering, Pembangunan Nasional “Veteran” Jawa timur University

## Abstract

Laundry waste is a biodegradable material that very suitable to use to biological processes. Downflow Hanging Sponge (DHS) is one of them. DHS is a biological treatment with an attached growth method. DHS uses a sponge medium that provides a three-dimensional space in which microorganisms can grow. The purpose of this study was to determine the effectiveness of laundry waste treatment in reducing pollutant levels using DHS so that it meets the quality standards. The variables used in this study are media, debit, and Hydraulic Retention Time (HRT). The results of the research showed that cellulose sponge media with 3 hours of HRT was the most optimum in reducing COD in the range of 62- 90%, BOD in the range of 56-82%, TSS in the range of 80-92%, Phosphate in the range of 21-72%, and also MBAS with a range of 27-76%.

**Keywords:** Downflow Hanging Sponge (DHS), Laundry Wastewater, Biofilter, Three-Dimensional Space, HRT

## INTRODUCTION

The population in Indonesia has grown quite rapidly over time from 260 million in 2017 to 270 million in 2022 [1,2]. This resulted in population density, especially in big cities. One of the most densely populated cities in Indonesia is Surabaya with 18 percent of the total population [3]. This is a promising business area, especially in the laundry business. The large number of laundry businesses are not accompanied by proper wastewater treatment so that the waste produced is directly discharged into water bodies [4]. This has a negative impact on the waters because it causes turbidity, inhibits oxygen transfer, and blocks sunlight from entering the water [5].

Waste water originating from the laundry business is classified as domestic

liquid waste originating from washing water such as soap, detergent, softener, and clothes fragrance [6]. In general, laundry businesses tend to use detergent rather than soap because detergent produces more foam which is believed to remove dirt faster than soap[7].

Laundry waste contaminants contain detergents and fabric softeners which contain active ingredients such as quaternary ammonium chloride, LAS, sodium dodecyl benzene sulfonate, sodium carbonate, sodium phosphate, alkylbenzene sulfonate [8,9]. These materials are environmentally friendly and biodegradable. However, in excessive quantities, laundry waste has the potential to contaminate water bodies. Because laundry waste is a biodegradable

material so that it is very suitable for processing using biological processes. One suitable biological treatment is using Downflow Hanging Sponge (DHS) [10,11,12,17].

The DHS reactor is recommended as an efficient and cost-effective technology. In addition, the DHS reactor system has high performance in processing activated sludge which is achieved by microbial stratification which is useful for reducing organic compounds (13). One of the main advantages of the DHS system is that although the treatment system is aerobic, no external aeration is required [14]. It is suitable to be applied to the laundry business, where does not have more capital to build a wastewater treatment. Referring to East Java Governor Regulation Number 72 of 2013 concerning Wastewater Quality Standards for Industry and or Other Business Activities, it states that every Industry and or other business activity is required to carry out wastewater treatment so that the quality of the discharged wastewater does not exceed the wastewater quality standard [15,18].

Due to these problems, this research is aimed at creating a laundry wastewater treatment unit using a Downflow Hanging Sponge (DHS) bioreactor. Through this research, it can be seen how efficient DHS is in reducing the pollutant load of laundry

waste. This research is expected to be a guideline for making waste treatment units in the current laundry business.

**METHODOLOGY**

Down-flow Hanging Sponge (DHS) is a system in wastewater treatment. The use of the DHS reactor system was developed by Prof. Harada at Nagaoka University of Technology, Japan [16]. This system is designed to be applied as a wastewater treatment unit in developing countries that require a low-cost system with easy operation and maintenance. In addition, this system is designed to reduce sludge production from a wastewater treatment plant system. The concept of using this system is adopting the trickling filter system, but using a material made of sponge [17]. Sponges become a supporting medium for various microorganisms by providing longer cell occupancy, increasing air diffusion into the wastewater, and reducing the need for external aeration, therefore DHS is unlike most existing aerobic systems [18]. To date, six different types of sponge configurations for DHS have been developed. Apart from treating domestic waste, DHS has also been used to treat several types of industrial waste [19]. The DHS concept has evolved from the first to the sixth generation (Figure 1)

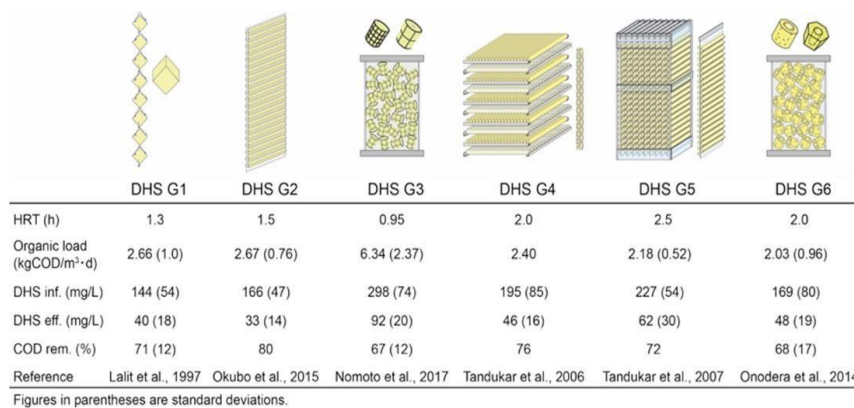

**Figure 1** DHS performance with different types of sponge in waste treatment [19]

The design of the Down-flow Hanging Sponge Reactor in this study can be seen in Figure 2 below. The process sequence follows the following stages:

### 1. Seeding

This process is carried out to breed bacteria or microorganisms that will be used to degrade several content parameters in the waste, following this stages:

- a) Laundry waste water from the laundry business is placed in a waste container
- b) Flow the waste water downflow in each reactor using a pump for 24 hours continuously
- c) Measure the COD value every 3 days
- d) Observe the development of biofilm on the media, if the media has not grown, it is necessary to add nutrients
- e) If the biofilm has grown and the COD value has decreased, proceed to the acclimatization stage

### 2. Acclimatization

The acclimatization process is carried out with the aim of obtaining a microorganism culture that is stable and can adapt to the liquid waste being tested. Steady state conditions are conditions where the removal of organic matter removed by microorganisms approaches a stable or constant number [20]. The acclimatization process followed these stages below:

- a) Laundry waste water from the laundry business is placed in a waste container
- b) Flowing wastewater downflow in each reactor using a pump for 24 hours continuously
- c) Measure the COD value every 3 days, if the COD value experiences a relatively stable decrease, the difference is no

more than 10%, then the microorganism is in a steady state condition.

- d) If the microorganism is already in a steady state, then proceed to the running stage

### 3. Running

The running process aims to find the most effective variation of Hydraulic Retention Time (HRT) and the type of media in treating laundry wastewater using a downflow hanging sponge. The stages of the running process include:

- a) Prepare 4 reactors. Reactor 1 contained media A with a HRT of 1 hour, reactor 2 contained media A with a HRT of 3 hours, reactor 3 contained media B with a HRT of 1 hour, reactor 4 contained media B with a HRT of 3 hours (Figure 3)
- b) Laundry waste water from the laundry business is placed in a waste container
- c) Conduct an experiment to measure the velocity of water entering each reactor to find the desired debit, namely: reactors 1 and 3 are 166.7 mL/minute; reactors 2 and 4 were 55.5 mL/min
- d) After finding the right valve opening position, downflow of waste water is carried out in each reactor using a pump.
- e) After the wastewater has collected in the effluent tub, sampling is carried out by testing the parameters COD, BOD, TSS, Phosphate, MBAS and PH.
- f) Repeat from step b to e for 30 days with parameter testing every 5 times a day

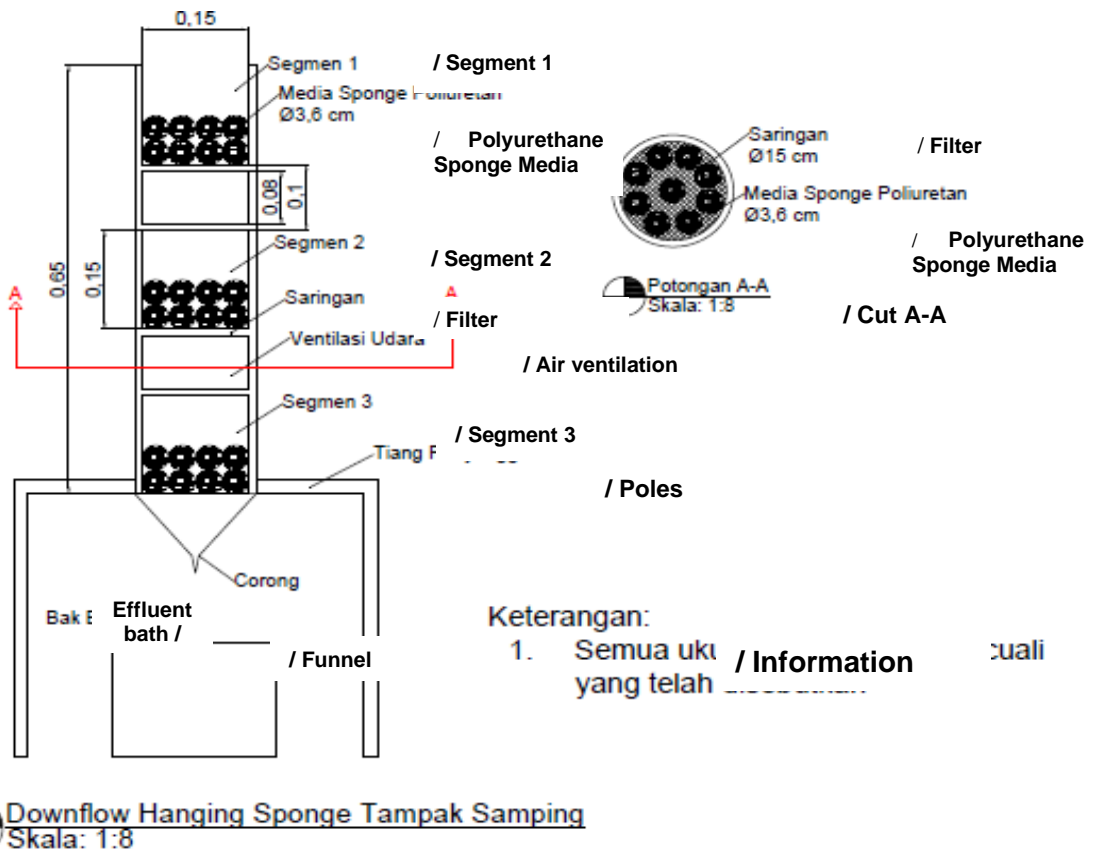

Figure 2 Design of downflow Hanging flow

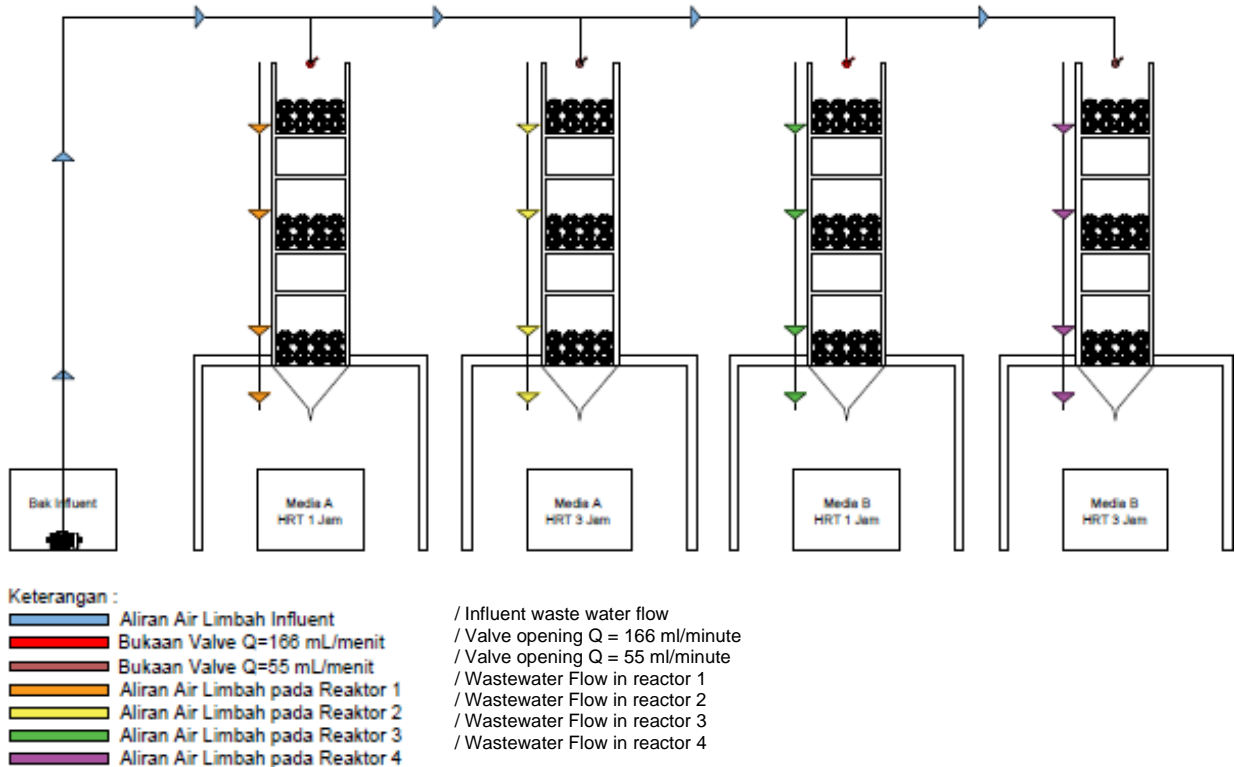

Figure 3 Reactor for running process



Media A  
(Biofilter ball)

Media B  
(Sponge tube)

**Figure 4** Waste treatment media

## RESULTS AND DISCUSSION

The following are the results obtained from the research that has been done

### I. Laundry waste content before treatment

**Table 1** Laundry waste content before treatment

Day	Waste content					
	COD (mg/L)	BOD (mg/L)	TSS (mg/L)	Fosfat (mg/L)	MBAS (mg/L)	pH
5	492.8	153.6	200	132	24.3	7.8
10	584.32	177.6	240	123	28,8	8
15	420.32	144	200	72.5	16.9	8.5
20	538.72	168	220	83.6	20.1	8.7
25	692.64	163.2	280	55.9	9.35	7.7
30	728.64	177.6	280	21.4	6.62	7.5

### II. Seeding and Acclimatization process

After the initial preparations have been made, the important steps before processing the Down-flow Hanging Sponge are seeding and adaptation of the

seeds to the media (acclimatization). The process is carried out by flowing the laundry wastewater continuously into the DHS reactor media for 24 hours. the results of seeding and acclimatization can be shown as follows (Table 2).

**Table 2** Seeding dan Acclimatization Process

Day	In	Ef	% Removal
3	583.2	316.8	45.68%
6	583.2	288	50.62%
9	583.2	187.2	67.90%
12	1288.2	597.2	53.64%
15	1288.2	482.4	62.55%
18	561.6	208.8	62.82%
21	561.6	180	67.95%
24	561.6	129.6	76.92%

As depicted in Table 2 it was found that the COD removal on day 3 had a percentage of 45.68% and increased on day 9 of 67.9% but visually, the media still did not have a biofilm layer so that on day 12, in the waste bosam sludge is added as a nutrient. This addition resulted decreasing the efficiency by 14.26%. On the 15th day, it was visually found that the media had grown a clear membrane. This indicates that the biofilm layer on the media has been formed. On the 18th day, the biofilm layer began to thicken which indicated that the microorganisms could accept the wastewater. But before processing, acclimatization must be carried

out with the aim that microorganisms can adapt. After several days of COD testing, the COD test value experienced a steady increase with a difference of no more than 10% so that it can be conclude that the microorganism is in a steady state.

### III. Concentration of Laundry Wastewater Contaminants on the Variation of Residence Time

The analysis is done to compare the removal efficiency of the laundry wastewater parameters from each reactor. The goal is to find the effective residence time when treating wastewater (Table 3).

**Table 3** Efficiency of Allowance Parameters for Laundry Wastewater Processed by Downflow Hanging Sponge

		Media A				
HRT	Day	BOD (%)	COD (%)	TSS (%)	Phosphate (%)	MBAS (%)
1 hour	5	50.00	58.57	70.00	21.97	24.28
	10	64.86	63.86	75.00	20.98	48.26
	15	63.33	70.42	70.00	26.07	56.04
	20	71.43	75.82	81.82	42.70	71.54
	25	79.41	81.20	85.71	65.47	50.91
	30	72.97	78.79	92.86	59.44	58.01
3 hous	5	59.38	64.29	80.00	22.65	28.40
	10	75.68	71.08	83.33	25.77	48.26
	15	76.67	78.87	80.00	29.93	65.92
	20	77.14	84.62	90.91	43.54	77.86

	25	85.29	88.89	92.86	68.69	60.64
	30	78.38	85.86	92.86	66.40	61.93
Media B						
	5	40.63	57.14	70.00	20.53	24.69
	10	51.35	75.90	75.00	24.88	45.49
1	15	63.33	73.24	80.00	25.24	61.66
hour	20	74.29	78.02	81.82	41.39	72.94
	25	76.47	82.05	78.57	69.05	62.78
	30	70.27	78.79	92.86	61.78	49.55
	5	56.25	62.86	80.00	21.36	27.98
	10	64.86	81.93	83.33	33.82	52.08
3	15	70.00	84.51	90.00	36.69	68.93
hous	20	80.00	86.81	90.91	47.25	76.97
	25	82.35	90.60	85.71	72.09	63.32
	30	72.97	86.87	92.86	64.30	60.42

For each data taken, a normality test was carried out and it was found that the data was normally distributed. To obtain the most effective HRT value in treating laundry wastewater using Downflow Hanging Sponge, a One-Way ANOVA Test was performed.

ANOVA result from media A and media B shows that the best HRT in treating laundry wastewater using a downflow hanging sponge is 3 hours. This happens because the longer the liquid residence time, the longer the wastewater is in the system, as a result the contact time between the biomass in the reactor and the substrate is also getting longer. Thus the degradation process progresses better, so that the percentage of degradation also increases. This theory is in line with research conducted by [10,11,12,19].

One Way ANOVA test was also carried out to find out which was the best between polyuretenes. It was found that cellulose sponges were better than polyurethane sponges even though their efficiency values were not significantly different.

## CONCLUSION

In this study, After conducting this research, laundry wastewater has exceeded wastewater quality standards and can be directly disposed of in water bodies. Using One Way ANOVA test obtained that the best removal efficiency is at 3 hours HRT with the COD parameters in media A and B are 88.89% and 90.60%, the BOD parameters on media A and B are 85.29% and 82.35%, the TSS parameter in media A and B is 92.86% 92.86%, The phosphate parameters in media A and B are 68.69% and 72.09%, and the MBAS parameters on media A and B are 77.86% and 79.97%. From One Way ANOVA test on cellulose sponges and polyurethane sponges, its is obtained that cellulose is the best alternative to be used in treating laundry wastewater using DHS.

## Acknowledgement

The authors fully acknowledged Ministry of Higher Education (MOHE) and Universiti Sains Malaysia for the approved fund which makes this important research viable and effective.

The author acknowledged Ministry of Education, Culture, Research, and Technology and UPN Veteran Jatim which made this research carried out and obtained the expected results. We also very grateful to all parties who have helped in this research directly or indirectly.

## References

### REQUIRED AMOUNT ARE AT LEAST 20 REFERENCES

Using the Simple Text Query form to deposit references :

<https://doi.crossref.org/simpleTextQuery>

- [1] Mardiansjah FH, Rahayu P, Rukmana D. 2021. New patterns of urbanization in Indonesia: Emergence of non-statutory towns and new extended urban regions. *Environment and Urbanization ASIA*. 12(1): 11-26. DOI : <https://doi.org/10.1177/0975425321990384>
- [2] Wulan DR, Hamidah U, Komarulzaman A, Rosmalina RT, Sintawardani N. 2022 May. Domestic wastewater in Indonesia: Generation, characteristics and treatment. *Environmental Science and Pollution Research*. 29(22): 32397-414. DOI : <https://doi.org/10.1007/s11356-022-19057-6>
- [3] Indrayani, E., & Wasistiono, S. 2021. The role of community protection institution in disaster management at West Java, Indonesia. *Jambá: Journal of Disaster Risk Studies*, 13[1]: 1-10. DOI : <https://doi.org/10.4102/jamba.v13i1.943>
- [4] Harahap J, Gunawan T, Suprayogi S, Widyastuti M. 2021. A review: Domestic wastewater management system in Indonesia. *In IOP Conference Series: Earth and Environmental Science 2021*, Apr. 739(1): 012031. IOP Publishing. DOI : <https://doi.org/10.1088/1755-1315/739/1/012031>
- [5] Fito J, Tefera N, Van Hulle SW. 2019, Dec. Sugarcane biorefineries wastewater: bioremediation technologies for environmental sustainability. *Chemical and Biological Technologies in Agriculture*. Dec 6 :1-3. DOI : <https://doi.org/10.1186/s40538-019-0144-5>
- [6] Ho KC, Teow YH, Sum JY, Ng ZJ, Mohammad AW. 2021, Mar. Water pathways through the ages: Integrated laundry wastewater treatment for pollution prevention. *Science of the Total Environment*. 15(760) :143966. DOI : <https://doi.org/10.1016/j.scitotenv.2020.143966>
- [7] Koohsaryan E, Anbia M, Maghsoodlu M. 2020, Oct. Application of zeolites as non-phosphate detergent builders: A review. *Journal of Environmental Chemical Engineering*. 8(5):104287. DOI : <https://doi.org/10.1016/j.jece.2020.104287>
- [8] Azizullah A, Khan S, Rehman S, Taimur N, Häder DP. 2021. Detergents Pollution in Freshwater Ecosystems. *Anthropogenic Pollution of Aquatic Ecosystems*. 245-270. DOI : [https://doi.org/10.1007/978-3-030-75602-4\\_12](https://doi.org/10.1007/978-3-030-75602-4_12)
- [9] Achaw OW, Danso-Boateng E. 2021 Aug. Soaps and Detergents. *In*



- Chemical and Process Industries: With Examples of Industries in Ghana.* 10 : 1-37. Cham: Springer International Publishing.  
DOI : [https://doi.org/10.1007/978-3-030-79139-1\\_1](https://doi.org/10.1007/978-3-030-79139-1_1)
- [10] Imachi H, Nobu MK, Miyazaki M, Tasumi E, Saito Y, Sakai S, Ogawara M, Ohashi A, Takai K. 2022, Dec. Cultivation of previously uncultured microorganisms with a continuous-flow down-flow hanging sponge (DHS) bioreactor, using a syntrophic archaeon culture obtained from deep marine sediment as a case study. *Nature Protocols.* 17(12) : 2784-814.  
DOI : <https://doi.org/10.1038/s41596-022-00735-1>
- [11] Choerudin C, Arrahmah FI, Daniel JK, Watari T, Yamaguchi T, Setiadi T. 2021 Aug. Evaluation of combined anaerobic membrane bioreactor and downflow hanging sponge reactor for treatment of synthetic textile wastewater. *Journal of Environmental Chemical Engineering.* 9(4):105276.  
DOI : <https://doi.org/10.1016/j.jece.2021.105276>
- [12] Watari T, Hata Y, Hirakata Y, Nguyet PN, Nguyen TH, Maki S, Hatamoto M, Sutani D, Setia T, Yamaguchi T. 2021, Feb. Performance evaluation of down-flow hanging sponge reactor for direct treatment of actual textile wastewater; Effect of effluent recirculation to performance and microbial community. *Journal of Water Process Engineering.* 1(39):101724.  
DOI : <https://doi.org/10.1016/j.jwpe.2020.101724>
- [13] Maharjan AK, Kamei T, Amatya IM, Mori K, Kazama F, Toyama T. 2020, Feb. Ammonium-nitrogen (NH<sub>4</sub><sup>+</sup>-N) removal from groundwater by a dropping nitrification reactor: characterization of NH<sub>4</sub><sup>+</sup>-N transformation and bacterial community in the reactor. *Water.* 22;12(2):599.  
DOI : <https://doi.org/10.3390/w12020599>
- [14] Tyagi VK, Ali M, Tawfik A, Maharjan N, Kazmi AA, Okubo T, Harada H. 2021, June. Future perspectives of energy saving down-flow hanging sponge (DHS) technology for wastewater valorization-a review. *Reviews in Environmental Science and Bio/Technology.* 20: 389-418.  
DOI: <https://doi.org/10.1007/s11157-021-09573-1>
- [15] Dewi IA, Mustaniroh SA, Fajriani S, Subagiyo A. 2021, Dec. The Effect of Material Characteristics on the Quality of Hand-crafted Batik Wastewater. In *International Conference on Innovation and Technology (ICIT 2021).* 64-69. Atlantis Press.  
DOI : <https://doi.org/10.2991/aer.k.211221.008>
- [16] Kirishima Y, Choisai P, Khotwieng W, Hatamoto M, Watari T, Choisai K, Panchaban P, Wong-Asa T, Yamaguchi T. 2022, Jul. Efficiency of high rate treatment of low-strength municipality sewage by a pilot-scale combination system of a sedimentation tank and a down-flow hanging sponge reactor. *Environmental Technology.* 16;43(16):2457-66.

- DOI :  
<https://doi.org/10.1080/09593330.2021.1882584>
- [17] Purwanda, E., & Achmad, W. (2022). Environmental Concerns in the Framework of General Sustainable Development and Tourism Sustainability. *Journal of Environmental Management & Tourism*, 13(7), 1911-1917.
- [18] Mariane, I., Erna, E., Yusuf, Y., Ardiati, R. L., & Achmad, W. (2022). Implementation of Good Environmental Governance in Handling Waste in Watersheds (DAS). *Res Militaris*, 12(2), 3455-3463.
- [19] Muliawaty, L., Firdausijah, R. T., & Achmad, W. (2022). Implementation of Waste Management Policies by the Main Waste Bank in Realizing the Effectiveness of the Waste Program in the City of Bandung. *resmilitaris*, 12(2), 1906-1913.
- [20] Nurmiyanto A, Ohashi A. 2019. Downflow hanging sponge (DHS) reactor for wastewater treatment-a short review. In *MATEC web of conferences*. 280: 05004. EDP Sciences.  
DOI :  
<https://doi.org/10.1051/mateconf/201928005004>
- [21] Hiep NT, Nga DT, Tuan PD. 2018, Aug. A research on the performance of down-flow hanging sponge (DHS) reactor treating domestic wastewater. *Vietnam Journal of Science and Technology*. 6;56(4):482-92.  
DOI : <https://doi.org/10.15625/2525-2518/56/4/10878>
- [22] Hatamoto M, Okubo T, Kubota K, Yamaguchi T. 2018, Dec. Characterization of downflow hanging sponge reactors with regard to structure, process function, and microbial community compositions. *Applied microbiology and biotechnology*. 102:10345-52.  
DOI : <https://doi.org/10.1007/s00253-018-9406-6>
- [23] Benis KZ, Behnami A, Aghayani E, Farabi S, Pourakbar M. 2021, Oct. Water recovery and on-site reuse of laundry wastewater by a facile and cost-effective system: Combined biological and advanced oxidation process. *Science of The Total Environment*. 1;789:148068.  
DOI :  
<https://doi.org/10.1016/j.scitotenv.2021.148068>